

## **SBA Technical Data Sheet Number 04 - The British National Hive**

Details of dimensions and construction for the DIY Beekeeper. Illustrations reproduced, and text modified, from Advisory Leaflet 367 - "The British National Hive", Published 1961, Reviewed and reprinted 1970. © Crown copyright; reproduced by permission of the controller of HMSO.

### **NOTE**

1. The design and dimensions of the National Single-walled hive are given in full in the specification issued by the British Standards Institution (British Standard 1300: 1960)

2. The information given here has been copied and summarised from the Ministry of Agriculture, Fisheries and Food Advisory leaflet 367, The British National Hive, Crown Copyright 1961, Reviewed 1970).

3. Almost all measurements are Imperial. They have not been converted to Metric equivalents as the original designs were specified in Imperial measurements. Anyone who wants to work in Metric equivalents may, of course, carry out the conversion for their own use.

### **Equipment**

Tools - hand (power tools optional)

### **Consumables**

- Timber - The original specification requires Western Red Cedar, but other softwoods are suitable provided the timber is well seasoned, sound, and free from large knots and rot.
- Wood Preservative - Colourless and odourless types, free from insecticide, are suitable. Cedar requires no preservative.
- Nails - assorted sizes
- Non-rusting metal sheet or other waterproof material (such as tar-felt) for covering the roof
- Metal Runners - these support the ends of the frames and are obtainable from bee appliance dealers. One pair is required for each brood box or super
- Queen Excluder - these are inserted between the brood box and honey supers, and are available, to BS specification, from appliance dealers
- Steel springs for follower board - these are available from appliance dealers as Section Rack Springs

### **Method of Preparation**

All wood should be cut and planed to size before trial fitting together. It may be advisable to pre-drill nail holes depending on the timber being used, if it is inclined to split. Exterior grade glue, though not absolutely essential, may be used to strengthen joints if desired. Preservative should be allowed to dry thoroughly before bees are introduced to the hive.

Method of Construction - General Principles

The hive consists of a floor with an entrance block, one or more deep (brood) boxes,

a crownboard, and a roof. Supers or section racks may be used for the storage of honey. The Deep box is designed to take up to eleven British Standard frames with long (1 1/2" ) lugs. The shallow box or super holds eleven shallow British Standard frames. The section rack is designed to take 32 sections 4 1/2" square. The roof is designed to provide a 1 1/4" ventilated, bee-tight air space above the crownboard. The floor is designed to be reversible, to provide a full width entrance 7/8" deep on one side or 3/8" deep on the other. It should be supported clear of the ground on bricks, or a stand of the type shown. The deep and shallow boxes may be placed on top of the floor and each other with the frames either parallel or at right angles to the entrance (so called 'warm' or 'cold' way), and the bee space is below the frames in each unit. (Minor modification is necessary to provide top bee space). The section rack fits flush onto the unit below it and a bee space is provided below the rack by the transverse strips which support the sections within the rack.

#### Method of Construction - Details

The separate parts of the hive are described in the following sections - each is illustrated, and there are accompanying notes for each part as well.

1. Floor
2. Entrance Block
3. Brood Chamber
4. Shallow Super
5. Crownboard
6. Roof
7. Section Rack
8. Hive Stand

### Constructional Details

#### 1 Floor

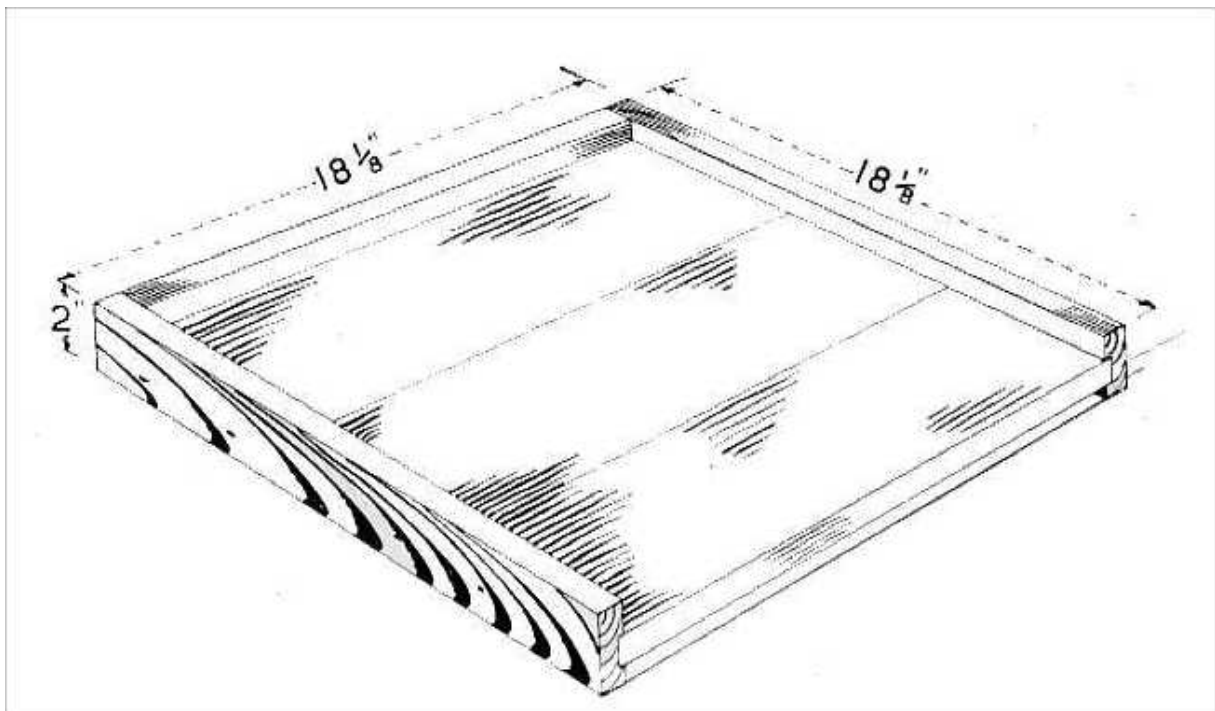

- external dimensions  $18 \frac{1}{8}''$  x  $18 \frac{1}{8}''$
- floorboards of  $\frac{3}{4}''$  thick timber, tongued and grooved or lapped joints
- floor timbers grooved  $\frac{1}{4}''$  into side rails  $\frac{3}{4}''$  thick and 2 " deep
- the grooves are  $\frac{3}{4}''$  wide,  $\frac{3}{8}''$  from one edge and  $\frac{7}{8}''$  from the other edge
- back is closed on each side with a strip of wood, one  $\frac{3}{8}''$  x  $\frac{7}{8}''$  x  $16 \frac{5}{8}''$ ; the other  $\frac{7}{8}''$  x  $\frac{7}{8}''$  x  $16 \frac{5}{8}''$ , nailed on at opposite ends

Fit the floorboards into the grooves of the side rails. Nail in from the outside of the side rails. Nail on the back strips, one on each side, with nails in at both ends.

## 2 Entrance Block

- The entrance block is only used when the floor has its deeper side uppermost.
- It is a fraction under  $\frac{7}{8}''$  square cross section and  $16 \frac{1}{2}''$  long, with a  $5''$  x  $\frac{5}{16}''$  central cut-away on one face. This allows it to be used to either regulate the entrance to  $5''$  wide, or to close off the entrance completely.
- Drive a staple into the inner face of the side rail on each side at the front of the floor,  $\frac{7}{8}''$  in from the front and leaving about  $\frac{1}{4}''$  of the staple projecting. This will prevent the block being accidentally pushed into the hive and out of reach.

## 3 Brood Chamber

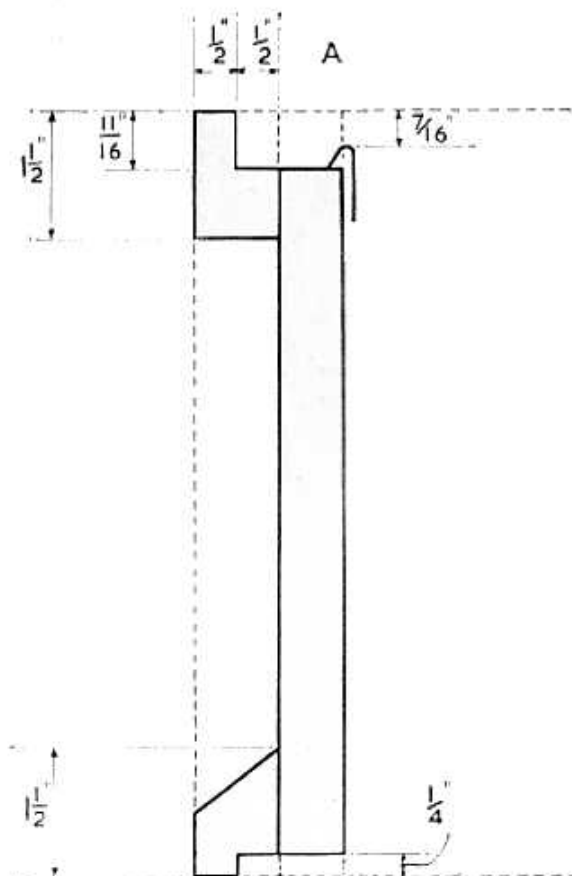
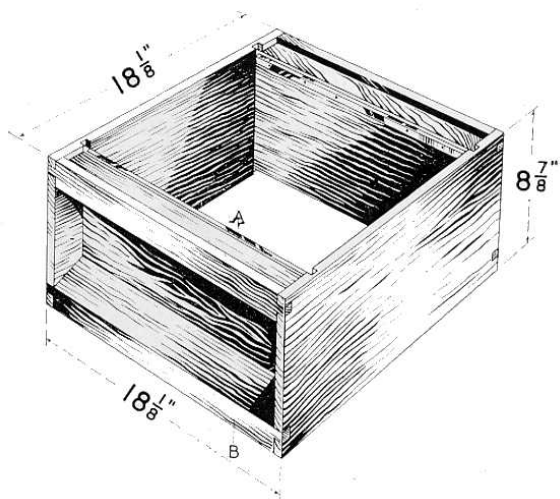

- external lateral dimensions  $18 \frac{1}{8}''$  x  $18 \frac{1}{8}''$
- depth  $8 \frac{7}{8}''$
- all four walls made from  $\frac{3}{4}''$  timber
- end walls are  $17''$  x  $7 \frac{15}{16}''$ , let into the side walls to a depth of  $\frac{3}{16}''$ , 1" from each end
- this 1" space between the outside surface of each end wall and the end of the side walls is closed with two fillets, one at the top and one at the bottom
- top fillet rebated on the inside  $\frac{11}{16}''$  deep from the top edge, leaving a shoulder  $\frac{1}{2}''$  wide - this rebate forms part of the recess which encloses the ends of the frame lugs

- bottom fillet rebated on the underside to a depth of 1/4" leaving a shoulder of 1/2" - this space provides the bee space above the frames in any box below
- upper surface of bottom fillet chamfered to shed the rain
- metal runners fitted along the top edge of the end walls with their top edge 7/12" below the top edges of the side walls of the box

Fit the end walls into the grooves in the side walls and nail into them through the grooves. It is vital to make sure that the end walls finish 1/4" short of the side walls at the bottom, and that the metal runners for the frame lugs lie 7/16" below the top edges of the side walls. Fit and nail the four rebated fillets, the chamfered ones at the bottom.

As with other hive parts, exterior grade glue may be used if desired to strengthen the joints, and it may be useful to pre-drill the nail holes if the wood is tending to split.

To convert to top bee space

Omit the 1/4" rebate from the bottom fillet, and make the rebate on the top fillet 15/16" deep (still leaving a 1/2" shoulder). When assembling, the bottom of the end walls fits flush with the bottom of the side walls, and the top edges of the metal runners finish up 11/16" below the top edges of the side walls.

#### **4 Shallow Super**

The construction of the super is identical to that of the brood chamber, except that the overall depth is 5 7/8". Please refer to the illustrations for the Brood Chamber, but note the difference in depth.

- external lateral dimensions 18 1/8" x 18 1/8 "
- depth 5 7/8"
- all four walls made from 3/4" timber
- end walls are 17" x 4 15/16", let into the side walls to a depth of 3/16", 1" from each end
- this 1" space between the outside surface of each end wall and the end of the side walls is closed with two fillets, one at the top and one at the bottom
- top fillet rebated on the inside 11/16" deep from the top edge, leaving a shoulder 1/2" wide - this rebate forms part of the recess which encloses the ends of the frame lugs
- bottom fillet rebated on the underside to a depth of 1/4" leaving a shoulder of 1/2" - this space provides the bee space above the frames in any box below
- upper surface of bottom fillet chamfered to shed the rain
- metal runners fitted along the top edge of the end walls with their top edge 7/16" below the top edges of the side walls of the box

Fit the end walls into the grooves in the side walls and nail into them through the grooves. It is vital to make sure that the end walls finish 1/4" short of the side walls at the bottom, and that the metal runners for the frame lugs lie 7/16" below the top edges of the side walls. Fit and nail the four rebated fillets, the chamfered ones at the bottom.

As with other hive parts, exterior grade glue may be used if desired to strengthen the joints, and it may be useful to pre-drill the nail holes if the wood is tending to split.

To convert to top bee space

Omit the 1/4" rebate from the bottom fillet, and make the rebate on the top fillet 15/16" deep (still leaving a 1/2" shoulder). When assembling, the bottom of the end walls fits flush with the bottom of the side walls, and the top edges of the metal runners finish up 11/16" below the top edges of the side walls.

## 5 Crownboard

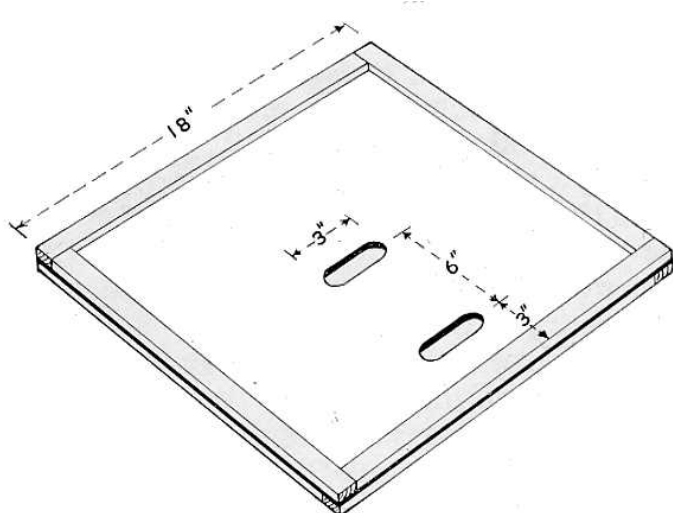

- overall dimensions 18" x 18"
- made from softwood at least 3/8" thick and with rebated or tongued and grooved joints, or resin-bonded plywood at least 5mm thick
- a bee space of 1/4" on each side by framing with four strips of softwood 17 1/8" x 7/8"
- strips so arranged that at any corner the joint on one face is at right angles to the corresponding corner joint on the other face (see illustration)
- alternatively the board

may be rebated into a frame of such thickness that a 1/4" bee space is provided on each side

- two openings in the board 1 1/16" x 3" adapted to receive Porter bee escapes, one centrally and the other parallel to it with its centre 3" from the edge of the board

Fit the edge strips to the board noting the arrangement of the strips at the corners carefully. Again, glue may be used - bear in mind that if the crownboard is stuck down well by the bees it may require significant levering from a hive tool to dislodge it.

To convert to top bee space

If the board is used over a top bee space arrangement, it will be found that the edge strips on the underside of the board should be omitted, as otherwise the bees will build brace comb above the frames in the additional space provided if the strips are present. The strips on the upper face of the crownboard, for use when it doubles as a clearing board, should in this case be 3/8" thick rather than 1/4".

## 6 Roof

- inside measurement of roof 18 3/4" x 18 3/4" x 5 3/4".
- top boards not less than 3/8" thick, and side walls not less than 1/2" thick
- corners should be lock jointed and nailed both ways
- if using halved joints for the corners, the timber should be not less than 5/8" thick, but note that this will make the roof heavier

- roof covered with non-rusting metal or other waterproof material extending not less than 1 1/2" down the side
- four wooden strips each 18" long and 1 1/4" x 3/4" cross section, fitted round the top inside to give a head space of 1 1/4" above the crown board
- ventilation holes 3/4" diameter bored centrally through the sides of the roof and spacing strips, and backed with perforated zinc or non-rusting wire mesh

Assemble the four sides of the roof , taking care to nail the corners in both directions,

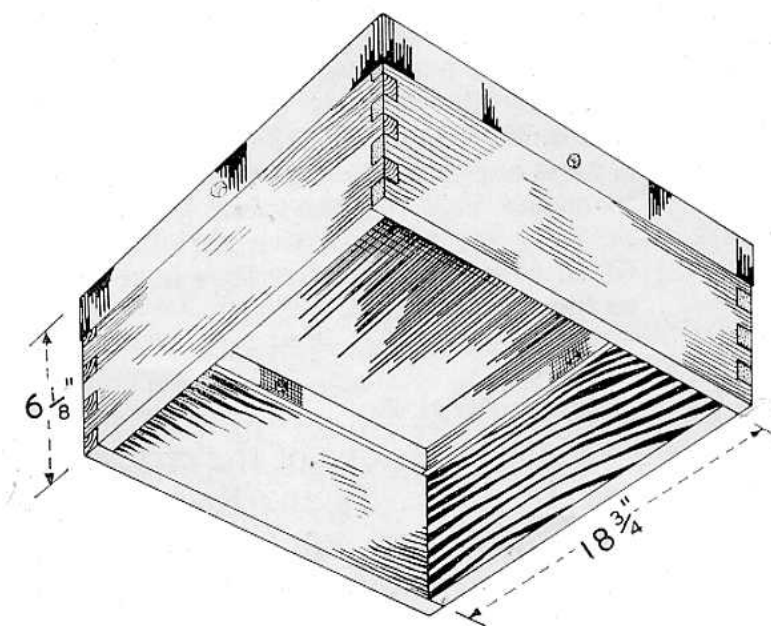

then fit the top boards, nailing them through onto the side boards along all four sides. Next fit the four strips to provide the head space, then cover with waterproof cover (metal or tarred felt) before completing the ventilation holes.

Some beekeepers omit the ventilation holes believing them not to be necessary. Others also make the roof somewhat deeper, to give added insulation to the brood box in winter as the sides of the roof extend down further over the brood

box, and thus effectively provide thicker walls to the hive. However these modifications are not a part of the Standard Specification.

### 7 Section Rack

The overall dimensions of a British National hive are such that the section rack does not contain its thirty two sections exactly - there is a small amount of 'dead space'. This space has to be inaccessible to the bees, and there has also to be a mechanism for holding the sections tightly in place. hence the need for a spring loaded follower board, and some strips of wood on the underneath of the rack.

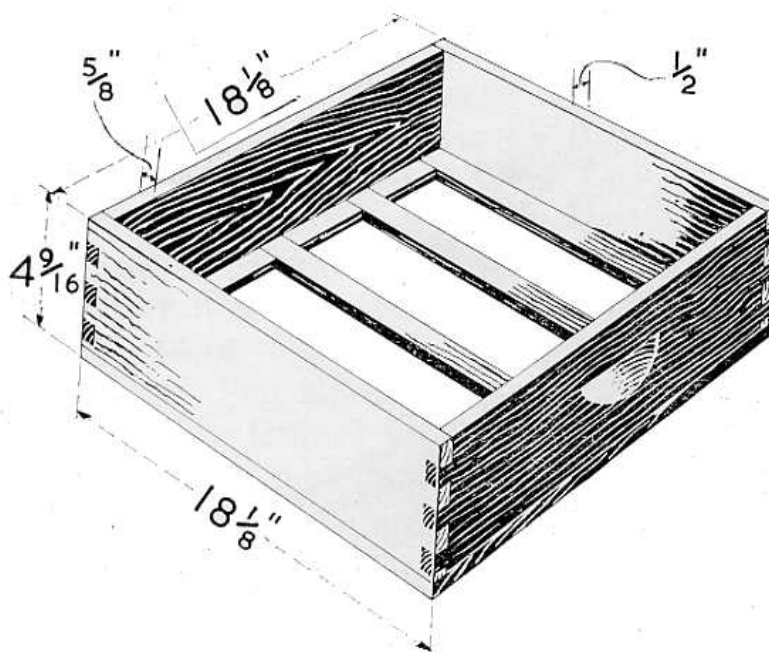

- outside dimensions 18 1/8" x 18 1/8"
- side walls made from two pieces 1/2" thick timber, 18 1/8" x 4 5/16"
- end walls made from two pieces 5/8" thick timber
- corners lock-jointed and nailed both ways
- this gives internal dimensions 17 1/8" x 16 7/8" x 4 5/16".
- thirty-two sections held in four rows of eight, held tight by a follower board 17" x 4 1/4" x 3/8", supported by two steel springs (obtainable from appliance dealers)
- sections rest on five wooden strips
- two strips 18 1/8" x 1 1/16" x 1/4"
- three strips 18 1/8" x 1" x 1/4"
- the wider strips used under the the 1/2" thick walls
- the narrower ones with their ends spaced out equally across the bottom of the 5/8" thick walls and running parallel to the 1/2" thick walls
- these strips interspersed by four other pieces of wood nailed along the bottom edges of the 5/8" thick boards
- four pieces 3 1/4" x 1/2" x 1/4" at one end
- four pieces 3 1/2" x 2" x 1/4" at the other end where the follower board lies (these wider strips prevent bees from below getting in behind the follower board)
- the strips below result in an overall depth of 4 9/16"
- D-shaped finger grips may be cut into the end walls

Start by lock-jointing and nailing the four corners together. The long strips can then be fixed in place by nailing, but take care to space them exactly otherwise the shorter pieces will not fit correctly. Finish by inserting the follower board and springs when the sections are put in place.

### 8 Hive Stand

Most beekeepers will place hives on individual stands made from bricks, concrete blocks or old railway sleepers, or on a slatted wooden stand designed to take a number of hives. However for those who wish to make a custom stand for the National hive, the details are given below. In order to reduce the risk of rotting however, this stand should probably still be placed on bricks or similar rather than directly on the earth. It has the advantage however of providing the bees with an alighting board.

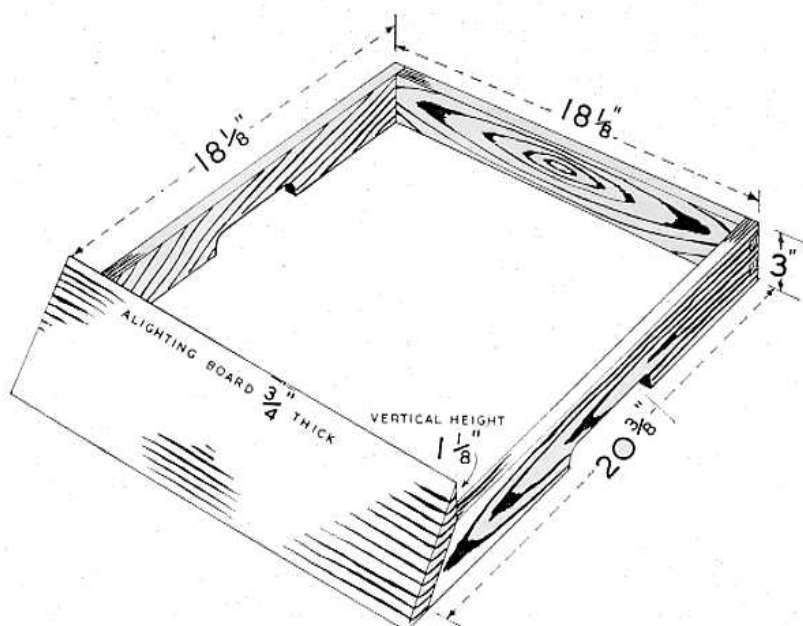

- outside dimensions 18 1/8" x 18 1/8"
- construct from 3/4" timber
- side rails have cut-away for hand holds
- alighting board fits flush against front of floor

Nail back and two sides together, then fit alighting board at front

### **Health and Safety Information**

The following hazards are identified:

1 Danger or personal injury from:

1. Hand tools
2. Power tools
3. Hammer and nails

### **Precautions:**

1. Protective overall and gloves
2. Goggles

DISCLAIMER: - Great care has been taken in the preparation of this technical sheet to ensure accuracy but the Scottish Beekeepers' Association cannot accept liability or responsibility. Beekeepers must therefore use the information at their own discretion and risk.

### **Acknowledgements:**

Illustrations reproduced, and text modified, from Advisory Leaflet 367 - "The British National Hive", Published 1961, Reviewed and reprinted 1970. © Crown copyright; reproduced by permission of the controller of HMSO.

**ISSUE NO 2 DATED FEBRUARY 2007**